

Pin style, 10 mm², single pole busbar, Bent 90° / Stiftstil, 10 mm², einpolige Sammelschiene, 90° gebogen / Estilo de pin, 10 mm², barra colectora de un polo, 90° doblado

IZS10/1F/L



TECHNICAL DATA / TECHNISCHE DATEN / DATOS TÉCNICOS		
U_e	Nominal voltage / Bemessungsspannung / Tensión nominal de conexión	240 [V]
U_i	Rated insulation voltage / Bemessungsisolationsspannung / Tensión nominal de aislamiento	500 [V]
I_e	Max. current / max. Schienstrom / Capacidad de carga de corriente	63 [A]
U_{imp}	Surge voltage / Bemessungsschossspannung / Tensión nominal de choque tolerada	4 [kV]
	Material of insulation / Werkstoff für Isolierung / Material de aislamiento	PVC-U
	Material of conductor / elektrisches Leitermaterial / Material de conductor	Cu-ETP

Standard Variants (customable lengths) / Standardvarianten (anpassbare Längen) / Variantes estándar (longitudes personalizables)

TYPE TYP TIPO	CROSS-SECTION QUERSCHNITT SECCIÓN [mm ²]	MODULE DIMENSION MASS MODULE DIMENSIONES DEL MÓDULO [mm]	LENGTH* LÄNGE LONGITUD* [mm]	MODULES (LENGTH) MODULE (LÄNGE) MÓDULOS (LONGITUD)	CATALOGUE NUMBER KATALOGNUMMER NÚMERO DE CATÁLOGO	PACKAGING / VERPACKUNG / EMBALAJE	
						Single package / Packungsstück / Embalaje individual [pcs]/[kg]	Collective packaging / Sammelverpackung / Embalaje colectivo [pcs]/[kg]
IZS10/1F/12/L	10	17,8	216	12	0210011912	40/1,75	480/21,02
IZS10/1F/24/L	10	17,8	429	24	0210011924	40/3,50	
IZS10/1F/54/L	10	17,8	963	54	0210011954	40/7,88	
IZS10/1F/57/L	10	17,8	1017	57	0210011957	40/8,32	

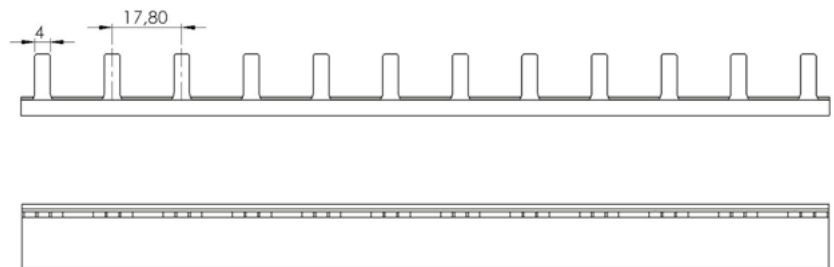
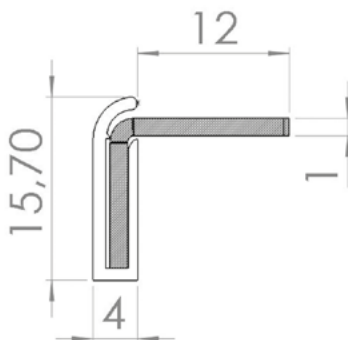

ACCESSORIES / ZUBERHÖR / ACCESORIOS

ENDCAP / ENDKAPPE / TAPÓN	TYPE TYP TIPO	CATALOGUE NUMBER KATALOGNUMMER NÚMERO DE CATÁLOGO	PACKAGING / VERPACKUNG / EMBALAJE [pcs]/[kg]	PACKAGING / VERPACKUNG / EMBALAJE [box]/[kg]
	ZS-10/1F/L	18	/25/-0,015/	/250/-0,15/



Quality Control:



TÜV
Verified product
No: 000002385
www.cerifykat.tuv-nord.pl



IEC 60847-7-1:2009