

Fork Style, 16 mm<sup>2</sup>, single pole busbar, bent 90°, 6,2 screw. / Gabelstil, 16 mm<sup>2</sup>, einpolige Sammelschiene, 90° gebogen, 6,2 Schraube / Estilo de horquilla, 16 mm<sup>2</sup>, barra colectora de un polo, 90° doblado, 6,2 tornillo

### IZ16/1F/L6,2



TECHNICAL DATA / TECHNISCHE DATEN / DATOS TÉCNICOS		
<b>U<sub>e</sub></b>	Nominal voltage / Bemessungsspannung / Tensión nominal de conexión	240 [V]
<b>U<sub>i</sub></b>	Rated insulation voltage / Bemessungsisolationsspannung / Tensión nominal de aislamiento	500 [V]
<b>I<sub>e</sub></b>	Max. current / max.Schienstrom / Capacidad de carga de corriente	100 [A]
<b>U<sub>imp</sub></b>	Surge voltage / Bemessungsstosspannung / Tensión nominal de choque tolerada	4 [kV]
	Material of insulation / Werkstoff für Isolierung / Material de aislamiento	PVC-U
	Material of conductor / elektrisches Leitermaterial / Material de conductor	Cu-ETP

### Standard Variants (customable lengths) / Standardvarianten (anpassbare Längen) / Variantes estándar (longitudes personalizables)

TYPE TYP TIPO	CROSS-SECTION QUERSCHNITT SECCIÓN [mm <sup>2</sup> ]	MODULE DIMENSION MASS MODULE DIMENSIONES DEL MÓDULO [mm]	LENGTH* LÄNGE LONGITUD* [mm]	MODULES (LENGTH) MODULE (LÄNGE) MÓDULOS (LONGITUD)	CATALOGUE NUMBER KATALOGNUMMER NÚMERO DE CATÁLOGO	PACKAGING / VERPACKUNG / EMBALAJE	
						Single package / Packungseinheit / Embalaje individual [pcs]/[kg]	Collective packaging / Sammelverpackung / Embalaje colectivo [pcs]/[kg]
IZ16/1F/ 2/L6,2	16	17,8	38	2	0116012202	40/0,46	480
IZ16/1F/ 3/L6,2	16	17,8	55	3	0116012203	40/0,69	480
IZ16/1F/ 4/L6,2	16	17,8	73	4	0116012204	40/0,92	480

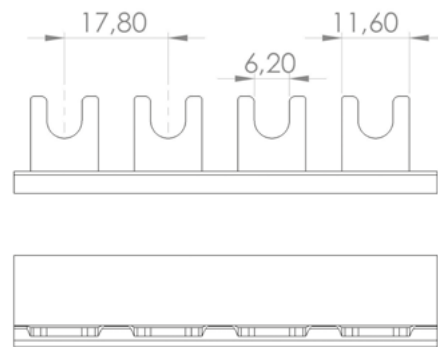
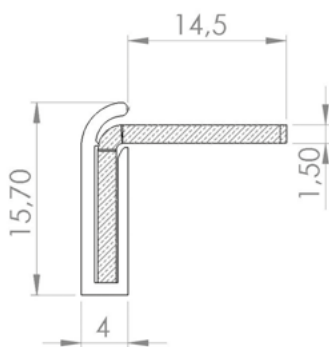

### ACCESSORIES / ZUBERHÖR / ACCESORIOS

ENDCAP / ENDKAPPE / TAPÓN	TYPE TYP TIPO	CATALOGUE NUMBER KATALOGNUMMER NÚMERO DE CATÁLOGO	PACKAGING / VERPACKUNG / EMBALAJE
			[pcs]/[kg] [box]/[kg]
	Z-16/1F/L	18	125/-0,005/ 1250/-0,050/

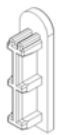

Quality Control:



**TÜV**  
Verified product  
No: 0000082365  
www.certhkat.tuv-nord.pl



IEC 60947-7-1:2009